

4 Wire Data with E&M DIN Fiber Link System

SYSTEM INSTALLATION INFORMATION

This industrial fiber optic media converter is designed to extend a 4 Wire Voice Frequency signal over fiber optic cable. By extending 4 Wire signals over fiber cable you gain the advantage of sending the signal long distances, up to 120km, as well as gain noise immunity to RF and electromagnetic interference.

This system transports one circuit of 4 Wire Data and supports E&M signaling. The 4 wire data supports constant transmission of voice frequency ranging from 300Hz-3400Hz which is suitable for a wide range of radio and SCADA applications. The devices can be ordered with dual fiber or single fiber transceivers. This RLH Fiber Link system is designed and made in the U.S.A. and covered by our **Limited Lifetime Warranty**.



4 Wire Data with E&M DIN Fiber Link

Key Features

- Hardened to operate in -40°F to +158°F (-40°C to +70°C)
- System power options: 24-48VDC and 125 VDC
- Multimode or single-mode fiber, and SC or ST connectors
- Single and dual fiber models available
- Built-in alarm relay to indicate system failure
- 4 wire voice frequency data systems
- Supports E&M
- Convenient LED status indicators
- **Made in the USA** covered by our **Lifetime Warranty**

Contents

Introduction	1
General Safety Practices	2
Special Handling Requirements	2
Acronyms	3
Applications	3
Installation	4
Operation	7
Status and Activity LED's	7
Specifications	8
Ordering Information	9

General Safety Practices

Intended Audience

This guide is intended for use by knowledgeable telco/network installation, operation and repair personnel. Every effort has been made to ensure the information in this guide is accurate. However, due to constant product improvement, specifications and information contained in this document are subject to change without notice.

Caution - Severe Shock Hazard

- Never install during a lightning storm or where unsafe high voltages are present.
- Active circuits may carry high DC voltages. Use caution when handling copper wiring.
- Remove the power source before making connections to this device.

Guidelines for handling terminated fiber cable

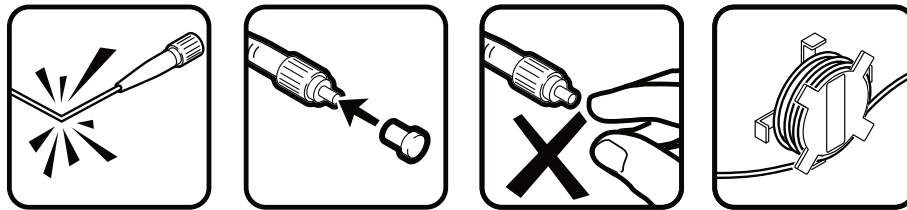

- Do not bend fiber cable sharply. Use gradual and smooth bends to avoid damaging glass fiber.
- Keep dust caps on fiber optic connectors at all times when disconnected.
- Do not remove dust caps from unused fiber connectors.
- Keep fiber ends and fiber connectors clean and free from dust, dirt and debris. Contamination will cause signal loss.
- Do not touch fiber ends.
- Store excess fiber on housing spools or fiber spools at site

Acronyms

Commonly used acronyms and abbreviations

Acronym/Abbreviation	Description
PBX	Private Branch Exchange
TX	Transmit
RX	Receive
MM	Multimode
SM	Single Mode
4W	Refers to 4 wire copper line
LED	Light Emitting Diode

Applications

Optical fiber is immune to EMI/RF interference, ground loops, and high voltage surges from lightning or ground faults, and is ideal for electrically noisy environments such as near large power sources, electrical motors, and radio communications equipment. Using fiber optic cable provides long distance service (up to 120km/74mi.) without any additional equipment.

Safety benefits of fiber optics

Placement of all-dielectric fiber optic cable (instead of copper) completely eliminates the presence of a remote ground, which dramatically increases safety of personnel and reliability of equipment. By using fiber optic cable, the DIN Fiber Link system provides absolute electrical isolation.

Application Diagrams

The diagram below shows a typical configuration of the 4 Wire Data with E&M system.

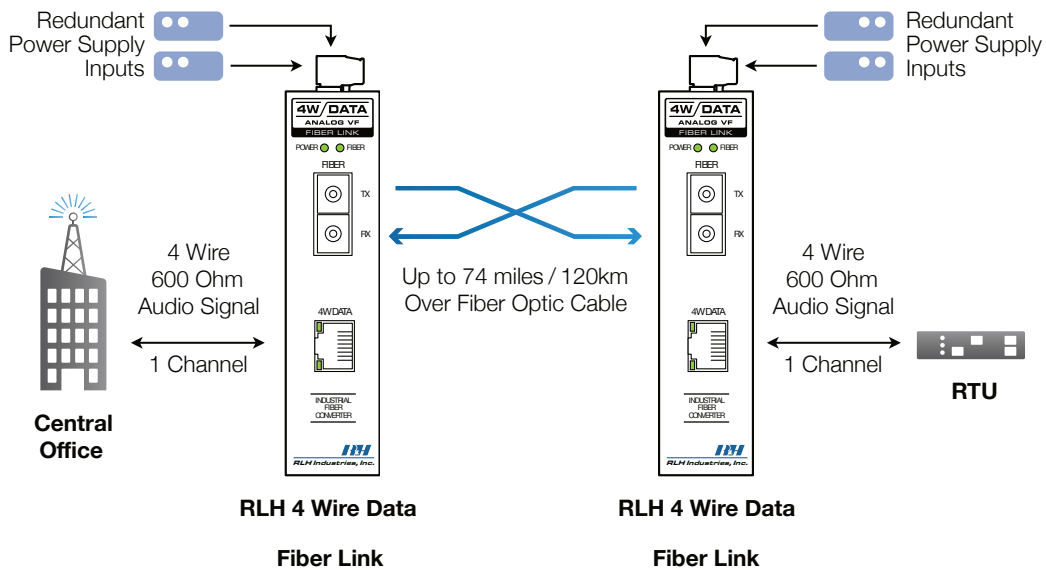

RLH 4 Wire Data with E&M Application Diagram

Installation

Prior to installation

- Check for shipping damage
- Check the contents to ensure correct model and powering options
- Make sure you have the correct fiber type and power available
- Have a clean, dry installation environment ready

Required for installation:

- Suitable wall, panel, or DIN rail space.
- Local power source (24~48VDC or 125VDC depending on model).
- Flat head screwdriver for connection wiring.
- Phillips screwdriver for attaching to wall (optional).

Physical layout

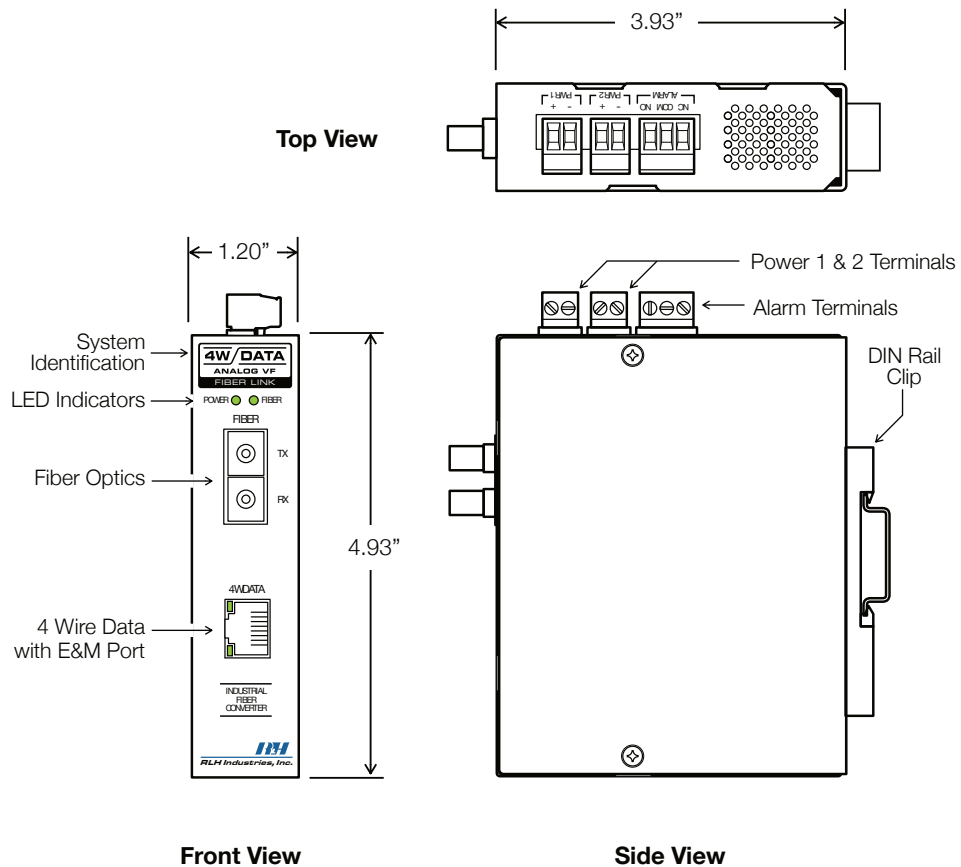

DIN rail mounting

The DIN clip for mounting the system is mounted onto the rear panel. Hook the DIN clip on the top flange of the DIN rail and rotate to the locked position to install. To remove, push up to depress the spring latch and rotate off of the DIN rail.

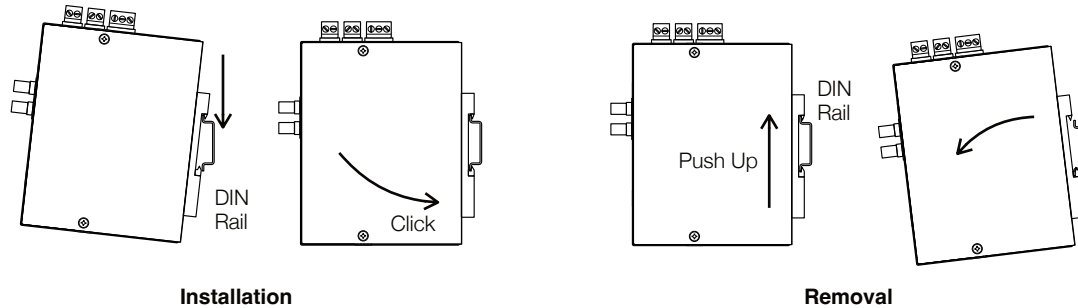

DIN Rail Mounting

Wall mounting

The system can be easily wall mounted by attaching the provided wall mount ears and hardware. Attach the wall mount ears by following the instructions below.

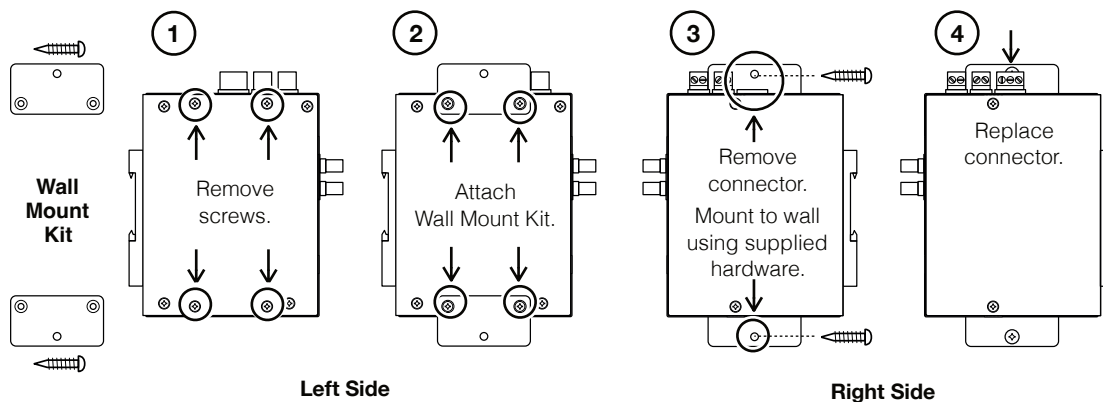

Wall Mounting

Connect optical fiber cable

The optical ports may be equipped with ST or SC fiber connectors. A fiber pair is required for operation with dual fiber models, TX is the output signal and RX is the input signal. Single fiber models combine input and output signals over one fiber strand.

Connect fiber cables to the correct TX and RX ports. On dual fiber models, the TX port of one side must be connected to the RX port of the unit at the other side. Make sure the connections are made accordingly at both ends of the Fiber Link.

Do not remove fiber cable caps until you connect the fiber to the unit. Exposing the mating optical interface to the surrounding environment should be limited to installation & maintenance only.

RJ-45 Pin List



RJ-45 Pin Chart		
E&M INPUT	1	Signal Battery, SB
	2	M-Lead
4 WIRE RX (Ring)	3	Ring, Audio Input, R
4 WIRE TX (Ring)	4	Ring, Audio Output, R1
4 WIRE TX (Tip)	5	Tip, Audio Output, T1
4 WIRE RX (Tip)	6	Tip, Audio Input, T
E&M OUTPUT	7	E-Lead
	8	Signal Ground, SG

Connect 4 Wire Data Pairs

The analog voice-frequency data transmission supports constant transmission of 300Hz to 3400Hz. Connect the TX pairs of the interfacing equipment to pins (3 & 6) of RLH fiber link and the RX pairs of the interfacing equipment to pins (4 & 5) of RLH fiber link. The TX pairs on each unit of RLH fiber link corresponds to the RX pair at the other end.

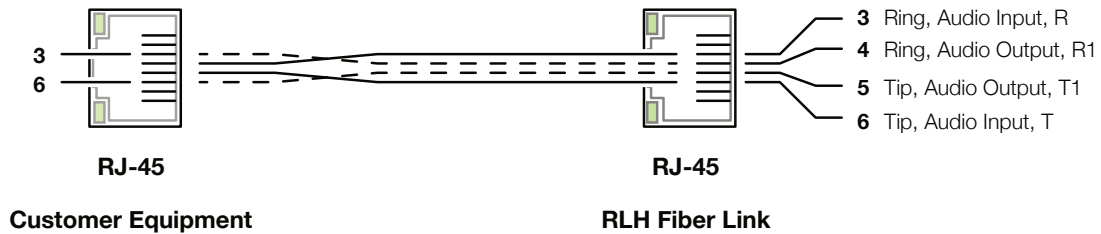

Connect E&M Leads

Connect the E&M leads to the E&M INPUT and E&M OUTPUT RJ-45 pins as illustrated below. The RECEIVE of one side corresponds to the SEND at the other end. The E&M input is activated by 24VDC, and can accept up to 48VDC.

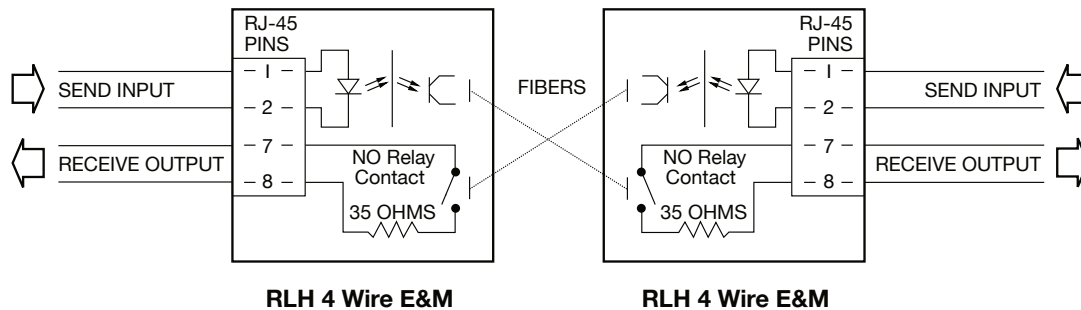

E&M operational status may be determined from the 2 status LED's located on the upper and lower ends of the RJ-45 Socket. The upper LED is ON when the input is active, and OFF when no input is present. The lower LED is ON when the E&M output is closed, and OFF when the output is open.

Connect Power

The system accepts a 24-48VDC or 125VDC local power source depending on the model. The power inputs are identified on the top of the device, near the alarm terminals and are labeled PWR 1 and PWR 2. Either or all of them may be used to power the device.

Connect the leads of the power source to the screw down terminals on top of the DIN device. For ease of installation, the terminal block may be removed by pulling it straight out. If removed, seat the terminal block firmly into the connector before applying power. Once power is applied the power LED will turn on.

Note: The power terminals are not polarity sensitive. The positive or negative lead of the power source may be connected to either terminal of the power connectors.

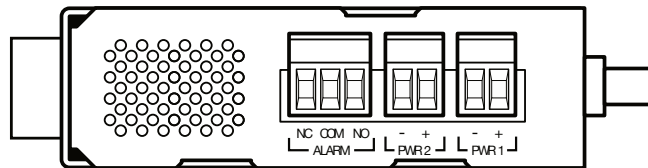

Detail of Power Terminals

Operation

The Wire Data with E&M system has two (2) green LED status indicators on the front panel of the device and two (2) green LED's on the RJ-45 port. Below is a table for a description of the LED indicators.

Status and Activity LED display

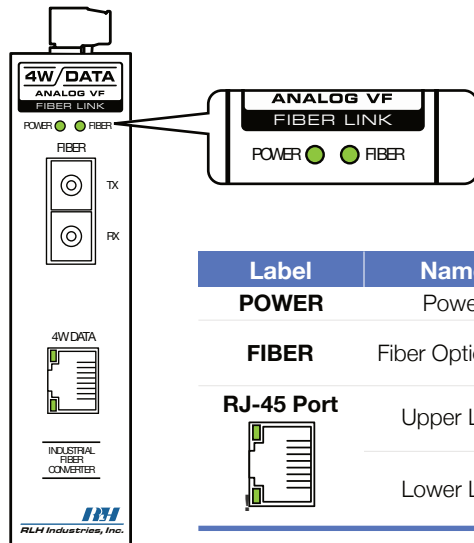

4W Data with E&M

Label	Name	Status	Description
POWER	Power	ON	System Power OK
		OFF	System Power is Inactive
FIBER	Fiber Optic Link	ON	Fiber Link is Connected
		OFF	Fiber Link is Disconnected
RJ-45 Port	Upper LED	ON	E&M Input is active
		OFF	E&M Input is inactive
	Lower LED	ON	E&M Output is active
		OFF	E&M Output is inactive

General Specifications

Transmission method	Frequency modulated light via two optical fibers
	Multimode: 1310nm
	Single-mode: 1310/1550nm
Maximum Fiber Loss / Distance*	Multimode: 1.25 mi. / 2km range
	Single-mode: 12.4 mi. / 20km range
	37 mi. / 60km range
	74 mi. / 120km range
	Single Fiber, Bi-directional
	Single-mode: 12.4 mi. / 20km range
	37 mi. / 60km range
	<i>*Note: Distances equated using industry standard fiber and connector attenuation. (Multimode: 3.5dB/km, Single-mode: 0.4db/km, + 0.5dB per connector, + 0.3dB per splice)</i>
Fiber Type	Multimode: 62.5/125µm, 50/125µm
	Single-mode: 9/125µm
Fiber Connector Types	ST or SC
Analog Bandwidth	300Hz to 3400Hz
Channel Noise	< 20dBmC (15dBmC typical)
Nominal Impedance	600 Ohm input and output
Insertion Loss	0dB +/- 0.5dB each direction
Signal Input Level	+8 to -16dBm
E&M Input	24-48VDC, 3000Vrms optically isolated
E&M Output	1500VRMS isolation by normally open solid state relay: Closed resistance 35 Ohms (220VAC or 330VDC @ 150mA max.) Open resistance >1M Ohms
Response Time	Input to output 15-18ms.
Surge Protection	PTC thermistors varistors
Power Requirements	24-56VDC
Power Consumption	6 Watts Maximum
Operating Temperature	-40° to +158° F (-40° to +70° C), 95% non-condensing
Dimensions	H 4.93" x W 1.20" x D 3.93" (not including DIN clip)
Warranty	Limited Lifetime Visit www.fiberopticlink.com for warranty details

Ordering Information

Each 4 Wire Data with E&M Fiber Link device is identified with a part number.

Optics	Distance	Fiber	Side	Part Number
Multimode SC	2km / 1.2 mi.	62.5/50µm	-	4D-1EM-03-1
Multimode ST	2km / 1.2 mi.	62.5/50µm	-	4D-1EM-04-1
Single-mode SC (Single Fiber)	20km / 12.4 mi.	8~9µm	A	4D-1EM-10-1
			B	4D-1EM-11-1
	60km / 37 mi.	8~9µm	A	4D-1EM-14-1
			B	4D-1EM-15-1
Single-mode SC	20km / 12.4 mi.	8~9µm	-	4D-1EM-40-1
	60km / 37 mi.	8~9µm	-	4D-1EM-41-1
	120km / 74 mi.	8~9µm	-	4D-1EM-45-1
Single-mode ST	20km / 12.4 mi.	8~9µm	-	4D-1EM-50-1
	60km / 37 mi.	8~9µm	-	4D-1EM-51-1
	120km / 74 mi.	8~9µm	-	4D-1EM-55-1

- ▶ A complete system requires 2 units.
- ▶ Add **-A** for 125 VDC Powering Option
- ▶ Please contact your RLH sales representative for pricing and delivery information.



RLH Industries, Inc.
 936 N. Main Street, Orange, CA 92867 USA
 T: (714) 532-1672
 F: (714) 532-1885

Please contact your RLH sales representative
 for pricing and delivery information.

Specifications subject to change without notice.