

4 Wire Data Fiber Link Card System

SYSTEM INSTALLATION INFORMATION

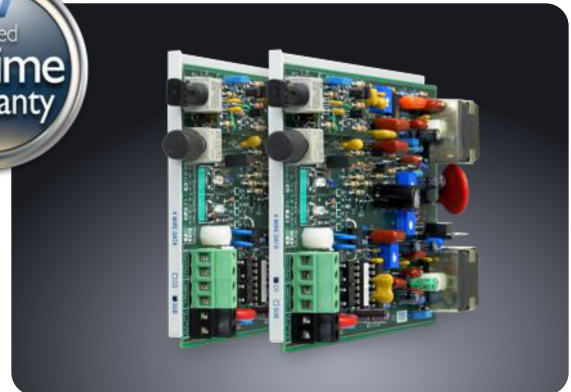

4 Wire Data Fiber Link Card

Description

The 4 Wire Data Fiber Link Card system provides a transmission of 4 wire data over two optical fibers. The 2 wire data is half duplex, and 4 wire data is full duplex. It supports full duplex constant transmission up to 9600bps (9.6Kbps) in voice-frequency or audio-tone range (300Hz-3.4KHz). LED indicators show fiber receive and power status.

Common applications include SCADA and protective relay systems. This hardened, rugged system may be installed into any of our card housings, and is covered by our **Limited Lifetime Warranty**.

4 Wire Data CO (Central Office) Side Card

The 4 Wire Data CO Card provides the electrical-optical interface between a Central Office or PBX 2/4 wire copper line and two fiber strands. The CO card is typically powered from Telco sealing current or line power (12mA minimum). If sealing current is not available the 4 wire Data CO card can be locally powered by a 24-56V DC power source. The power input is not polarity sensitive.

Note: The following Telco DST units can provide span through line powering to the 4 wire CO fiber card: Westell p/n's: 4368-02, 5496LG I2 (Verizon# 934461), 5497FA I3. The DST card must be installed into a Westell mounting assembly p/n: DAS296 or similar with SXR and SXT terminals. Refer to the DST 4W Wiring Instructions sheet for additional information.

4 Wire Data Sub (Subscriber) Side Card

The 4 Wire Data Sub Card provides the optical-electrical interface between the two fiber strands and a 2/4 wire copper line to a RTU, PBX, or modem. The Sub card is powered by a local 24-56VDC source, and can provide 18mA@24VDC output for powering customer equipment.

Contents

Description	1
General Safety Practices	2
Special Handling Requirements	2
Installation	3
Troubleshooting	5
Ordering Information	5
General Specifications	6

Compliance Information

The 4 Wire Data Fiber Link Card System is compliant with the following industry standards:

- **NEBS Level 3**
- **FCC PART-15**
- **FCC PART-68B**
- **IEEE-487**
- **IEEE-1590**
- **Motorola R56**
- **BR 876-310-100 BT (Telcordia)**
- **Bellcore SR-3966**
- **GR-1089**
- **GR-63**

General Safety Practices

The equipment discussed in this document may require tools designed for the purpose being described. RLH recommends that service personnel be familiar with the correct handling and use of any installation equipment used, and follow all safety precautions including the use of protective personal equipment as required.

Caution - Severe Shock Hazard

- Never install during a lightning storm or where unsafe high voltages are present.
- Active phone lines may carry high DC voltages. Use caution when handling copper wiring.

Special handling requirements

Be careful when handling electronic components.

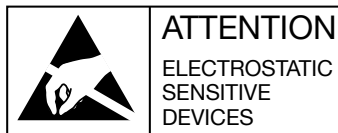

- This product contains static sensitive components.
- Handle the cards at their edges only.
- Follow proper electrostatic discharge procedures.

This card utilizes circuitry that can be damaged by static electricity. When transporting the card, carry it in an ESD safe container such as the antistatic bag provided with the card. Before handling cards, discharge yourself of static electricity by physical bodily contact with earth ground. When handling cards, hold by outer edges and avoid touching circuitry. Failure to follow ESD precautions may cause serious damage to the card and prevent proper operation.

Warning

The intra-building port(s) of the equipment or subassembly is suitable for connection to intra-building or unexposed wiring or cabling only. The intra-building port(s) of the equipment **MUST NOT** be metallically connected to interfaces that connect to the OSP or its wiring. These interfaces are designed for use as intra-building interfaces only (Type 4 ports as described in GR-1089-CORE, Issue 4) and require isolation from the exposed OSP cabling. The addition of Primary Protectors is not sufficient protection in order to connect these interfaces metallically to OSP wiring.

Guidelines for handling terminated fiber cable

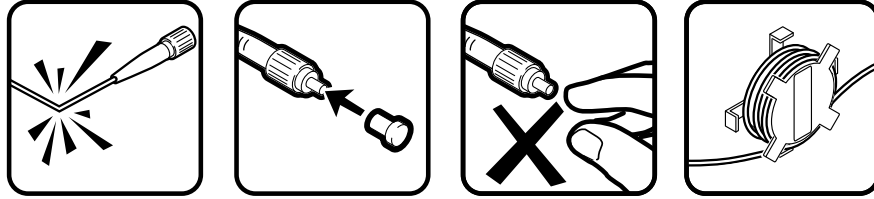

- Do not bend fiber cable sharply. Use gradual and smooth bends to avoid damaging glass fiber.
- Keep dust caps on fiber optic connectors at all times when disconnected.
- Do not remove dust caps from unused fiber.
- Keep fiber ends and fiber connectors clean and free from dust, dirt and debris. Contamination will cause signal loss.
- Do not touch fiber ends.
- Store excess fiber on housing spools or fiber spools at site

Installation

Prior to installation:

Check for shipping damage:

- Check the contents to ensure correct model and fiber type
- Have a clean, dry, installation environment ready

Required for installation:

- 24~56VDC (200mA@24VDC min.) local power source for the FXS/Sub card
- RLH Fiber Link card housing or enclosure
- A weatherproof enclosure is required for outdoor use

The 4 Wire Data card can be installed into any compatible RLH card housing. All electrical and fiber optic connection are made directly onto the card.

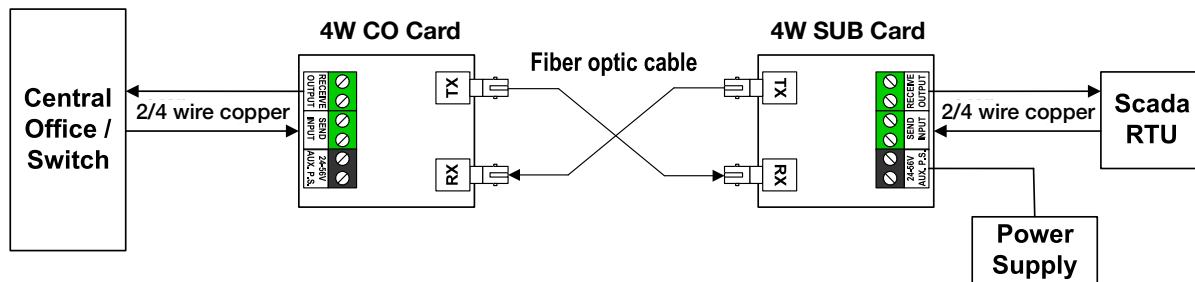

4 Wire Analog Data System Diagram

Connect fiber optic cable

Fiber Link Cards are equipped with two optical connectors. Connect fibers to the transmitter and receiver marked "TX" and "RX". For example, if fiber #1 is connected to "TX" on the CO Card, fiber #1 must be connected to "RX" on the Sub Card. Fiber cable should always be routed loosely avoiding tight bends.

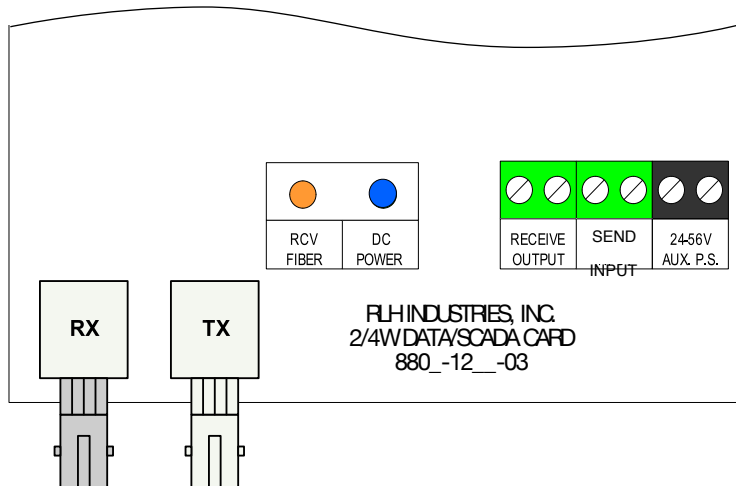

4 Wire Analog Data Card Connectors and LEDs

Label	Name	Color	Status	Description
RCV FIBER	Receive Fiber Signal	ORG	ON	Fiber connection detected
			OFF	Fiber connection not detected
DC POWER	DC Power	BLU	ON	Power is applied to the card
			OFF	Power is not present

► **Note:** Cards with WARR # lower than 625 do not have LEDs

Connect copper pair

The copper pair from the CO or PBX connects to the green SEND/INPUT screw-down terminal on the CO Card. The copper pair receive wires connect to the green RECEIVE/OUTPUT screw-down terminals. Connections are similar for the SUB side card. The input and output pairs must be connected to the correct terminals, however the individual tip/ring pairs are not polarity sensitive.

RJ-45 connectors

RJ45 adapters are available to connect cards via standard RJ connector, see figure 3. RJ jacks are gel filled to prevent corrosion. CO side RJ adapters connect pins 1,2 to the card input connector and pins 7,8 to the card output. Sub side RJ adapters connect pins 7,8 to the card input and 1,2 to the card output. Refer to the Ordering information for CO and SUB side RJ connector part numbers.

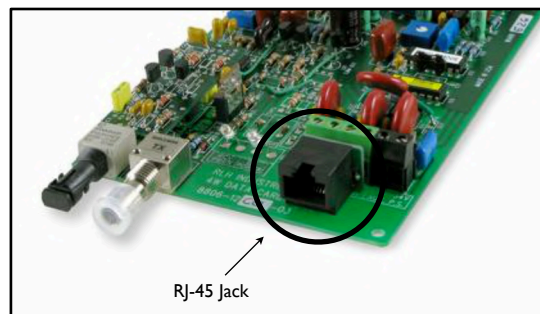

Card with RJ-45 Adapter

RJ-45Jack CO PIN 8 — PIN 1		RJ-45Jack SUB PIN 8 — PIN 1	
CO Card Pin Description		Sub Card Pin Description	
1 RX INPUT	5 Not Connected	1 TX OUTPUT	5 Not Connected
2 RX INPUT	6 Not Connected	2 TX OUTPUT	6 Not Connected
3 Not Connected	7 TX OUTPUT	3 Not Connected	7 RX INPUT
4 Not Connected	8 TX OUTPUT	4 Not Connected	8 RX INPUT

Connect Power

Connect a 24-56VDC (12mA minimum) power source to the black "AUX. P.S." screw-down terminal on the Card. The power input is not polarity sensitive.

Note: Local power is only required when simplex line power is not available on the wire pairs. Simplex power on the wire pair output is available on the SUB side as an option. Refer to the Ordering information.

Troubleshooting

If trouble is encountered, verify all installer connections, signal and voltage levels. If trouble persists, replace the unit and retest. If technical assistance is required, contact RLH Industries, Inc. Technical support department.

Ordering Information

Each 4 Wire Data card is identified with the part number.

Optics	Distance	Fiber	Description	Part Number	CLEI
Multimode ST	2km / 1.25 mi.	62.5µm	CO Card	8806-1235-03	VAUIASE9AA
			SUB Card	8806-1245-03	VAUIASB9AA
Single-mode ST	15km / 9 mi.	8~9µm	CO Card	8806-1279-01	NPIFCC01AA
			SUB Card	8806-1289-01	NPIFDC01AA
Single-mode SC	15km / 9 mi.	8~9µm	CO Card	8805-1279-01	LFT1AAMEAA
			SUB Card	8805-1289-01	LFT1AANEAA
Long Haul Single-mode ST	50km / 31 mi.	8~9µm	CO Card	8806-1279-01-LH	-
			SUB Card	8806-1289-01-LH	-
Long Haul Single-mode SC	50km / 31 mi.	8~9µm	CO Card	8805-1279-01-LH	-
			SUB Card	8805-1289-01-LH	-

- ▶ 62.5µm multimode fiber compatibility is standard, add **-50** to part number for 50µm fiber compatibility
- ▶ Add **-RJ** to part number for installed RJ45 adapter

General Specifications

Transmission method	Amplitude modulated light via two optical fiber
	Multimode: 850nm (Tx level: -26dB ± 1dB)
	Single-mode: 1310nm (Tx level: -29dB ± 1dB)
	SM Long Haul: 1310nm (Tx level: -6dB ± 2dB)
Maximum Fiber Loss / Distance*	Multimode: 8dB / 1.2 miles (2km)
	Single-mode: 8dB / 9 miles (15km)
	SM Long Haul: 26dB / 31 miles (50km); minimum 8dB
	Note: Distances equated using industry standard fiber and connector attenuation. Fiber condition, splices and connectors may affect actual range.
Fiber Type	Multimode: 62.5/125µm, 50/125µm ; Single-mode: 9/125µm
Fiber Connector Types	ST or SC
Wire Connector	Screw clamp, 12-26 AWG
Bandwidth	300 Hz to 3.4 KHz
Channel Noise	< 20dBmC (15dBmC typical)
DC Resistance Limits	2000 Ohms typical for 50V DC CO battery
Maximum Analog Data Rate	9600 bps (9.6 Kbps)
Maximum Latency (Over Fiber System)	250µs
Nominal Impedance	600 Ohm input and output
Insertion Loss	0dB +/- 0.5dB each direction
Signal Input Level	+8 to -16dBm
Surge Protection	PTC thermistors, zener diodes and varistors
Power Requirements	12mA-20mA @ 24-56VDC
Powering Method	Line or Local Power
Operating Temperature	-40° to +158° F (-40° to +70° C), 95% non-condensing
Dimensions	7"x4"x1" (Standard RLH Fiber Link Card form factor)
Warranty	Limited Lifetime <i>Visit www.fiberopticlink.com for warranty details</i>

Technical Support

Email:	support@fiberopticlink.com
24/7 technical support:	Toll Free 1-855-RLH-24X7 Toll Free 1-855-754-2497

RLH Industries, Inc.
936 N. Main Street, Orange, CA 92867 USA
T: (714) 532-1672
F: (714) 532-1885



Please contact your RLH sales representative for pricing and delivery information.

Specifications subject to change without notice.