



RLH Industries, Inc.

USER GUIDE

The leader in
rugged fiber optic
technology.

U-102 2024-0808

8 Channel Contact Closure DIN Fiber Link System

SYSTEM INSTALLATION INFORMATION

Description

The system provides transmission of eight (8) independent input signals over fiber optic cable. Applications include alarm event triggering, building automation, environmental control systems, fire & alarm systems, gate control, traffic signal control equipment, and more.

Fiber optic cable is immune to RF noise, high voltages, and extends the signal transmission range up to 100km. A complete system requires two (2) units, a 24-48VDC power source on each end, and two (2) matching SFP transceivers.

The Contact Input (TX) is configured with input terminals and the Contact Output (RX) has output relays. Each unit features a NC/NO alarm contact for system monitoring and convenient LED indicators to view system status. This hardened, rugged system is designed for standard T35 DIN rail mount applications, and is covered by our Limited Lifetime Warranty.

Contact Input - TX Unit

The input terminals have the ability to sense eight (8) independent contacts. The dry contact model makes installation of the unit quick and simple. Wet contact models have the ability to receive a wetting voltage, either between 12~24VDC or 24~48VDC, for each input.

Contact Output - RX Unit

Each output relay is paired with an Contact Input (TX Unit) on the opposite end of the system. The relay is configured Normally Open or Normally closed and for both these options the switching power is rated at 60Watts (DC or AC).



8 Channel Contact Closure System w/SFP

Standard Features

- 8 independent input signals over fiber
- Convenient LED status indicators
- Supports SFP Transceivers
- Inputs either sense a dry contact or receive a voltage
- Each Input terminal is optically isolated, 3.5kV
- Each output rated to support a load up to 60 Watts
- Redundant power inputs (24-48VDC)
- Pluggable terminal blocks
- Alarm contact for status monitoring
- Environmentally rugged with wide operating temp. -40°F to +158°F (-40°C to +70°C)
- Standard T35 DIN rail applications
- Limited Lifetime Warranty

Designed and Made in the U.S.A.

General Safety Practices

The equipment discussed in this document may require tools designed for the purpose being described. RLH recommends that service personnel be familiar with the correct handling and use of any installation equipment used, and follow all safety precautions including the use of protective personal equipment as required.

Caution - Severe Shock Hazard

- Never install during a lightning storm or where unsafe high voltages are present.
- Use caution when handling copper wiring and follow appropriate safety regulations.

Guidelines for Handling Terminated Fiber Cable

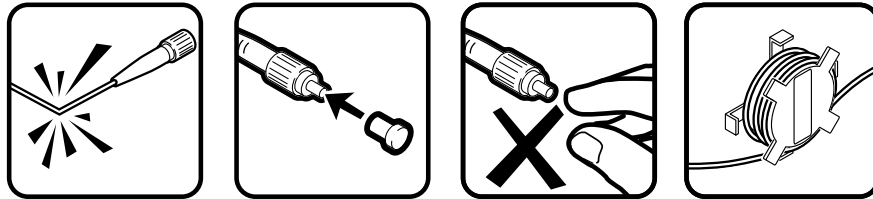

- Do not bend fiber cable sharply. Use gradual and smooth bends to avoid damaging glass fiber.
- Keep dust caps on fiber optic connectors at all times when disconnected.
- Do not remove dust caps from unused fiber.
- Keep fiber ends and fiber connectors clean and free from dust, dirt and debris. Contamination will cause signal loss.
- Do not touch fiber ends.
- Store excess fiber on housing spools or fiber spools at site

Acronyms

Commonly used acronyms and abbreviations

Acronym/Abbreviation	Description
TX	Transmit
RX	Receive
PWR	Power
CH	The logical connection between inputs and outputs
SFP	Small Form-factor Pluggable Transceiver
DRY	Input does not require voltage to sense a dry contact
WET	Input expects DC Voltage IN
Digital Input	An ON or OFF (1 or 0)
NO	Normally Open
NC	Normally Closed

Applications

By utilizing fiber optic cable, the 8 Channel Contact Closure DIN Fiber Link system provides absolute electrical isolation between both ends of the network. It is immune to EMI/RF interference, ground loops, and high voltage surges from lightning or ground faults, and is ideal in electrically noisy environments such as near large power sources, electrical motors, and radio communications equipment.

Additionally, the contact closure system allows the use of fiber cable infrastructure to transport relay alarms to and from locations being able to achieve distances of up to 100Km. Using a fiber optic contact closure system can simplify messaging and eliminate the need for a PLC or IED to transport the status of remote alarms and IO.

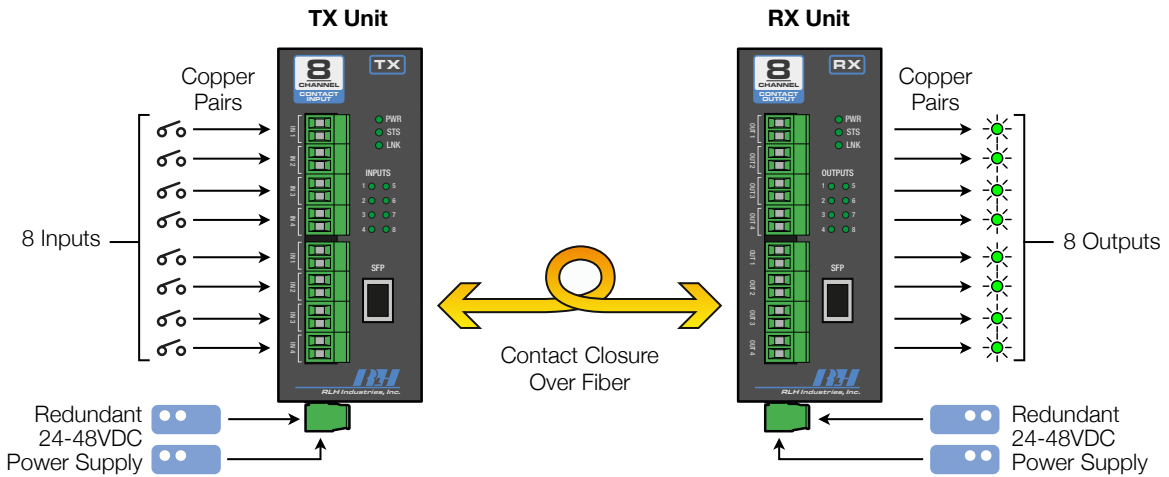

System Application Diagram

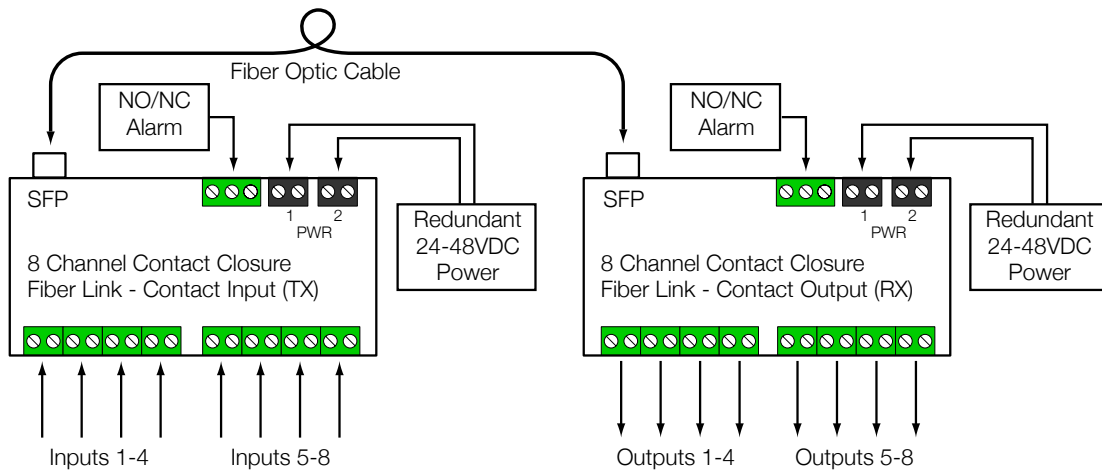

Single Fiber System Connection Diagram

Panel Layout

Front Panel

The front panel contains all the input and output contact terminals, LED's, and the fiber port.

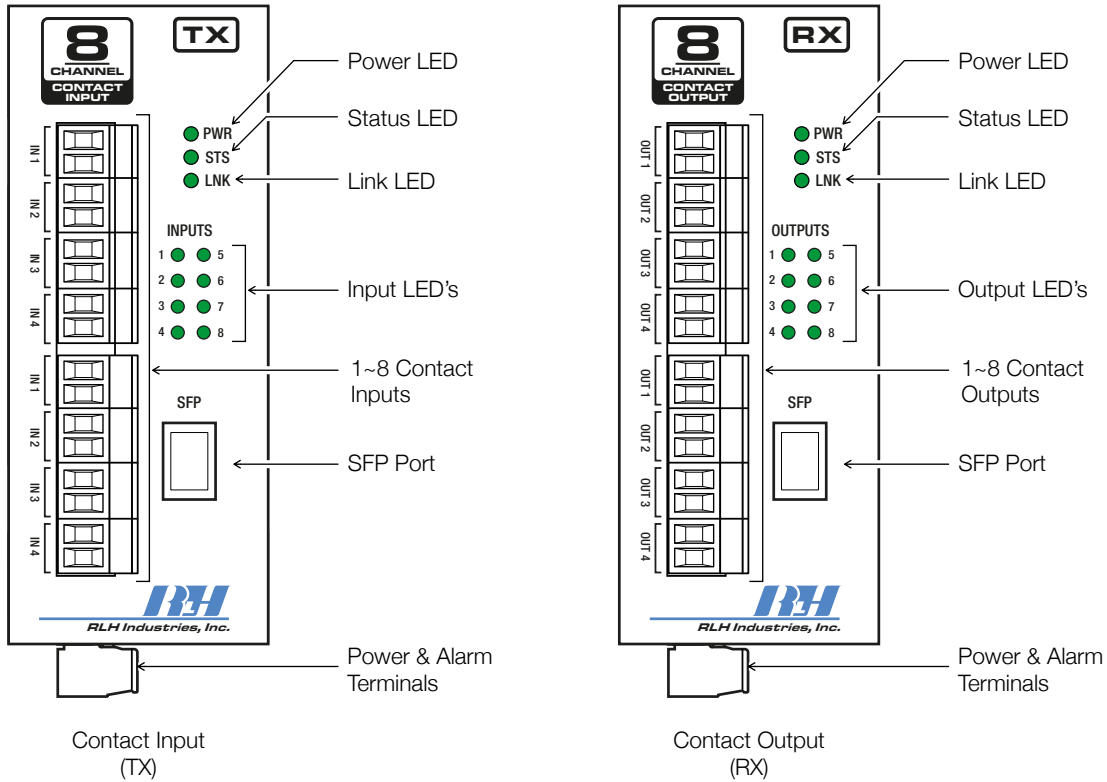

Front Panel Features

LED Identification

LED	Name	Color	Status	Condition
PWR	Power Failure	Green	ON	DC input power OK
			OFF	DC input power failed
STS	CPU Failure	Green	Blinking	CPU operating normally
			Solid (On or Off)	CPU failure
LNK	System Link	Green	ON	Paired via fiber connection
			OFF	Not paired
Inputs 1-8	Input Sensors	Green	ON	Input ON (Active)
			OFF	Input OFF
Outputs 1-8	Output Relays	Green	ON	Output is ON
			OFF	Output is OFF

System Alarm Contacts

- Alarms on power failure.
- Alarms when fiber links down.

Bottom Panel

The bottom panel contains the power and alarm terminals.

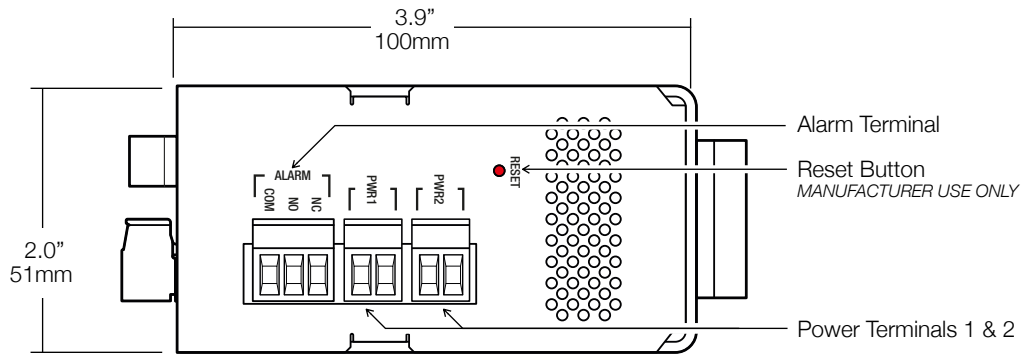

Bottom Panel Features

Rear Panel

The DIN clip for mounting the system is mounted onto the rear panel. Insert a flat head screwdriver into the release slot at the bottom of the DIN clip and pull down to remove the system from the DIN rail.

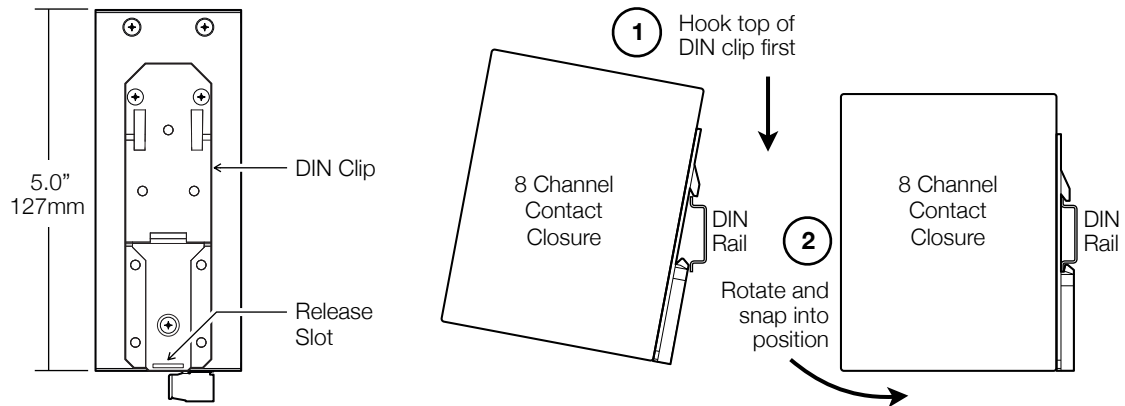

Rear Panel Features

DIN Rail Mounting

Installation

Prior to installation:

- Check for shipping damage.
- Check the contents to ensure correct model and fiber type.
- Have a clean, dry installation environment ready.
- Ensure that the SFP transceivers being installed in each unit are compatible.

Required for installation:

- 24-48VDC power source at both installation sites.
- DIN rail for mounting
- Multimeter

Measure the DC voltage of the source power to ensure that it is 24-48VDC. All electrical and fiber optic connection are made directly onto the unit.

Install SFP Transceiver

Verify the SFP transceivers compatibility. SFP's are sold separately, and compatible transceivers are listed in the *RLH Certified SFP Transceiver* section of this document.

- Dual fiber systems require identical SFP transceivers.
- Single fiber systems require a matching pair, side A and side B.
- Close clasp and slide the SFP transceiver into the port.
- To remove, pull the clasp back to release it, and then slide it out.

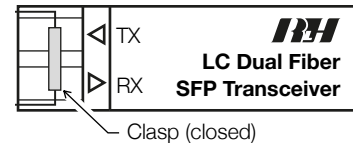

Connect Fiber Optic Cable

The optical ports are for use with SFP transceivers only. Remove the dust caps from the SFP transceiver and fiber connectors. Plug the cable(s) securely into the SFP.

- Dual fiber systems require the TX fiber port to be connected to the RX fiber port on the other end.
- Once the system is properly connected the Link LED should turn ON.

Connect Contact Wire Pairs

Connect the wire pair from each relay contact to the green screw-down terminals on the front.

DO NOT APPLY VOLTAGE to the contact terminals without verifying that you have the Wet input model or the system maybe damaged.

- The contact terminals may be removed and accept wire sizes 16~26 AWG.
- Fully seat the terminal block back into the connector before operating the system.

Dry Inputs

- Dry Inputs will sense a dry contact closure to trigger the Input.
- Check to ensure the copper pairs being used do not exceed 100 Ohms.
- Do not apply voltage to Dry Input terminals as the system may be damaged.

Wet Inputs

- Remove all voltage when wiring inputs.
- Wet inputs are NOT polarity sensitive. Connect + and - wire pair in any order.
- Channel assignments must match on the remote unit. *Example, Input 1 is paired with Output 1.*

Relay Outputs

- Remove power to the unit before installing or maintenance.
- Ensure the output relays maximum load of 60 Watts (AC or DC) is not being exceeded.
- Disconnect all power to load wiring prior to installation or maintenance

Alarm Wiring

Connect alarm relay monitoring equipment wire pair to the alarm contact on the bottom of the unit.

- Use the NO or NC contact positions as required.
- The alarm terminal block may be removed and accept wire sizes 16~26 AWG.
- Fully seat the terminal block back into the connector before operating the system.

Connect Power

Ensure power supply is OFF prior to wiring the system. Connect a 24-48VDC power supply to the screw-down terminals located on the bottom of the unit.

- Requires one (1) 24-48VDC power supply. Use a second power source for redundant power.
- Fully seat the terminal block back into the connector before operating the system.

Note: Both power inputs are NOT polarity sensitive.

Ordering Information

Each 8 Channel Contact Closure DIN Fiber Link unit is identified with a part number.

Description	Options	Part Number
8 Channel Contact Closure Input Contact - TX Unit	DRY	8CD-TX-DR-2
	WET (12~24VDC)	8CD-TX-24-2
	WET (24~48VDC)	8CD-TX-48-2
8 Channel Contact Closure Output Contact - RX Unit	Normally Open	8CD-RX-NO-2
	Normally Closed	8CD-RX-NC-2

- ▶ A complete system requires a pair of units. One (1) **TX** unit and one (1) **RX** unit.
- ▶ SFP Transceivers are sold separately. A list of compatible RLH Certified SFP's are listed below.
- ▶ Please contact your RLH sales representative for pricing and delivery information.

RLH Certified SFP Transceivers

Each 8 Channel Contact Closure DIN Fiber Link system requires a pair SFP Transceivers.

Description	Fibers	Mode	Side	Distance	Wavelength	Part Number
RLH Certified SFP Transceivers - 155Mbps - LC Connectors	Dual	MM	-	2km/1.2 mi.	1310nm	SFP-155-04-2
	Single	SM	A	20km/12.4 mi.	Tx1310nm/Rx1550nm	SFP-155-20-2
		SM	B	20km/12.4 mi.	Tx1550nm/Rx1310nm	SFP-155-21-2
	Single	SM	A	60km/37 mi.	Tx1310nm/Rx1550nm	SFP-155-24-2
		SM	B	60km/37 mi.	Tx1550nm/Rx1310nm	SFP-155-25-2
	Dual	SM	-	20km/12.4 mi.	1310nm	SFP-155-30-2
	Dual	SM	-	60km/37 mi.	1310nm	SFP-155-31-2
	Dual	SM	-	100km/62 mi.	1550nm	SFP-155-34-2

- ▶ Single fiber (bi-directional) SFP transceivers must always be paired, side **A** and side **B**.
- ▶ Please contact your RLH sales representative for pricing and delivery information

General Specifications

Fiber Connector Type	SFP Transceiver		
Compatibility	RLH Certified 155Mbps SFP's		
LED	PWR, STS, LNK, and Inputs 1~8 (TX) or Outputs 1~8 (RX).		
Power Input	24-48VDC (22~56V) Polarity Insensitive -A 125VDC (46~150V) -B 12VDC (11~30V) Dual redundant power inputs		
Power Consumption	6 Watts Max.		
Wire Connectors	Screw down terminal block, 16~26AWG		
Inputs 1~8	Dry (0-100 ohms) Wet (12~24VDC / 5mA) Optical isolation 3.5kV Wet (24~48VDC / 5mA)		
Outputs 1~8	Relay Contacts		
Output Relay Contacts Maximum Rating	115VAC	1.087A	125VA
	12VDC	3.000A	36 Watts
	24VDC	2.500A	60 Watts
	48VDC	1.250A	60 Watts
	130VDC	0.462A	60 Watts
	250VDC	0.240A	60 Watts
System Alarm Output	Normally Open / Closed Relay		
Relay Response Time	5ms typical, 10ms maximum		
Surge Protection	Varistors, Automatic resettable fuses		
DC Input Isolation	1.5kV		
Construction	Powder coated steel and aluminum alloy		
Mounting Style	Standard DIN rail (TS-35) mount		
Temperature	Operating -40°C ~ 70°C (-40°F ~ 158°F)		
Humidity	95%		
Dimensions/Mounting	H 4.93" x W 2.0" x D 3.93" (not including DIN clip or pluggable connectors) Standard T-35 DIN rail mounting		
Weight	1.4 lbs (0.63kg)		
Warranty	Limited Lifetime	Visit www.fiberopticlink.com for warranty details	



RLH Industries, Inc.
936 N. Main Street, Orange, CA 92867 USA
T: (714) 532-1672
F: (714) 532-1885

Please contact your RLH sales representative for pricing and delivery information.

Specifications subject to change without notice.