



Industrial Gigabit Ultra PoE++ Injector

Provide up to 90W of PoE and Gigabit Ethernet data transfer for Powered Devices

The RLH Industrial Gigabit Ultra PoE++ Injector simultaneously outputs power and Gigabit Ethernet data transmission to a connected Powered Device (PD). It can supply up to 90W of PoE in compliance with the IEEE 802.3af/at/bt standard's Type 4 PoE designation, supporting an extensive range of high-powered applications. A unique Flex Power feature enables this 90W PoE output to persist while the injector's power terminals receive an input voltage rated as low as 12VDC.

Its rugged, IP30-rated metal housing ensures that the injector can reliably operate in harsh industrial environments expressing temperatures between -40°C and 75°C. This injector's design supports multiple power input terminals for redundancy, a fault relay terminal that communicates the loss of a redundant power source, and status LEDs on the housing's front panel for the injector's system power and PoE output.

Injectors serve as an alternative power source and data transfer channel for Powered Devices when only non-PoE Ethernet switches are available in a network, or PoE switches are impractical to use. Injectors with PoE++ capabilities are ideal for applications with power-hungry PDs such as monitored PTZ IP cameras, gate and building access controllers, wireless access points, and thin clients. This RLH Injector is covered by our 5 Year Warranty.



Industrial Gigabit Ultra PoE++ Injector

Features

System

- Inject up to 90W of PoE (IEEE 802.3af/at/bt-compliant)
- Supports up to Gigabit Ethernet data transfer rates (10/100/1000Mbps)
- Flex Power - Constant 48VDC PoE++ output at low input voltages
- Power redundancy/failover and redundant power loss fault relay
- Supports Mode A, Mode B, and 4-Pair Mode PoE power relaying
- Status LEDs for the injector's system power and PoE output
- Overload current protection and reverse polarity protection
- "Plug and Play" system installation and usage

Environment

- Hardened to operate in -40°C to +75°C (-40°F to +167°F)
- DIN rail or Wall Mount (Wall mount ears included)

Power

- Redundant Power Inputs (9~55VDC)

Quality

- UL Listed
- TAA, NDAA and RoHS Compliant
- Highly reliable 762,640-hour MTBF
- Covered by our 5 Year Warranty



Application

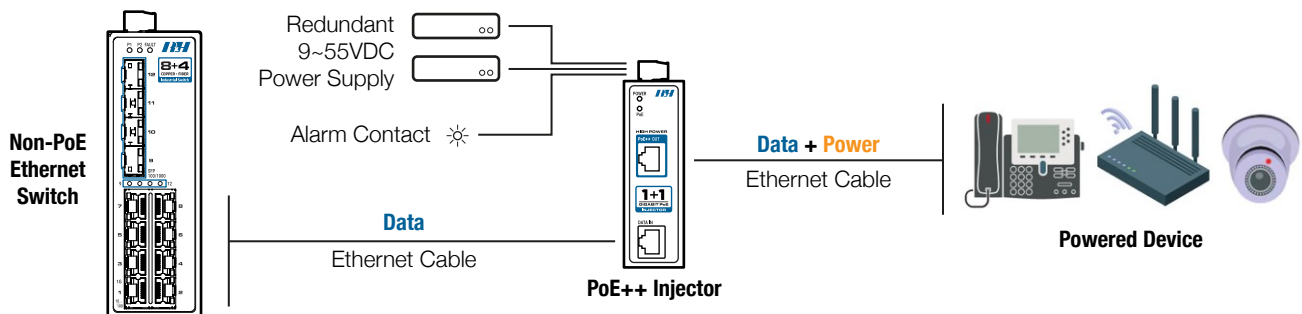



Key Specifications

Ethernet Ports	(Data) 10/100/1000Base-T(X)
	(Data + Power) 10/100/1000Base-T(X) with PoE++ (IEEE 802.3af/at/bt-compliant)
PoE Pinout	Mode A Pin 1 (V-), Pin 2 (V-), Pin 3 (V+), Pin 6 (V+)
	Mode B Pin 4 (V+), Pin 5 (V+), Pin 7 (V-), Pin 8 (V-)
	4-Pair Mode Pin 1 (V-), Pin 2 (V-), Pin 3 (V+), Pin 4 (V+), Pin 5 (V+), Pin 6 (V+), Pin 7 (V-), Pin 8 (V-)
	*This injector supports Mode A, Mode B, and 4-Pair Mode PoE relaying power schemes
LED Indicators	PWR Active power, with redundancy (GREEN) Active power, without redundancy (RED)
	PoE Active PoE supplied to the Powered Device (GREEN)
Alarm Relay Contact	24 VDC, 1A resistive Normally Open Relay (SPDT) (Redundant Power Status Alarm)
Network Cable Requirements	10Base-T 2-pair UTP/STP CAT3+ cable, EIA/TIA-568 100-ohm (100m/328ft maximum distance)
	100Base-TX 2-pair UTP/STP CAT5+ cable, EIA/TIA-568 100-ohm (100m/328ft maximum distance)
	1000Base-TX 4-pair UTP/STP CAT5e+ cable, EIA/TIA-568 100-ohm (100m/328ft maximum distance)
	*The total length between the two devices connected through the injector must not exceed 100m/328ft

General Specifications

Power Input	Dual 9-55VDC redundant power input terminals
Overload Current Protection	Present (slow-blow fuse)
Reverse Polarity Protection	Present (polarity insensitive power input terminal contacts)
Maximum Power Consumption	95 Watts (at full 90W PoE load)
Maximum PoE Output	60 Watts (at 9VDC power input)
	90 Watts (at 12-55VDC power input)
Housing	Metal, IP30 protection
Dimensions	H 1.2" x W 3.7" x D 3.0", (30mm x 95mm x 75mm) - not including DIN clip
Weight	0.79 lbs. / 0.36 kg (Unit Weight) 1.12 lbs. / 0.50 kg (Shipping Weight)
Mounting	Standard T-35 DIN rail clip and wall mount ears (Included)
Temperature	Storage -40°C to +85°C (-40°F to +185°F)
	Operating -40°C to +75°C (-40°F to +167°F)
Ambient Relative Humidity	5% to 95% (non-condensing)

Regulatory Specifications

EMI/EMS	FCC Part 15 Subpart B Class A, CE EN55032, CE EN55035, CE EN61000-4-2/3/4/5/6/8
Stability Testing	IEC60068-2-32 (Free Fall) IEC60068-2-37 (Shock) IEC60068-2-6 (Vibration)
Safety	UL 61010-1 and UL 61010-2-201, File Number: E544369
Green	RoHS Compliant
Responsible Sourcing	TAA and NDAA Compliant
MTBF	762,640 hours
Warranty	5 Years - Visit www.fiberoptick.com for warranty information and coverage details



Ordering Information

Description	Part Number
Industrial Gigabit Ultra PoE++ Injector, Powered by 9-55VDC	ETH-INJ-BT-1

Optional Accessories - Power Supplies

Description	Part Number
Industrial AC/DC + DC/DC Switching Power Supply, 24 Volts, 6.3 Amps, 150 Watts	AD1150-24F
Industrial AC/DC + DC/DC Switching Power Supply, 48 Volts, 3.2 Amps, 150 Watts	AD1150-48F
Industrial AC/DC + DC/DC Switching Power Supply, 24 Volts, 10 Amps, 240 Watts	AD1240-24C
Industrial AC/DC + DC/DC Switching Power Supply, 48 Volts, 5 Amps, 240 Watts	AD1240-48C

RLH Compatible PoE Powered Devices

Description	Part Number
Smart 4 Input Sensor, Rugged Ethernet IO Device for Monitoring and Alarming, Dry Contact Sensing	SM-IN4-DR-2
Smart 4 Input Sensor, Rugged Ethernet IO Device for Monitoring and Alarming, 5-15VDC Contact Sensing	SM-IN4-12-2
Smart 4 Input Sensor, Rugged Ethernet IO Device for Monitoring and Alarming, 24-48VDC Contact Sensing	SM-IN4-48-2
Smart 4 Relay Output, Rugged Ethernet IO Device for Monitoring and Alarming, Normally Open Relays	SM-OUT4-NO-2
Smart 4 Relay Output, Rugged Ethernet IO Device for Monitoring and Alarming, Normally Closed Relays	SM-OUT4-NC-2

Contact Information

By Mail:	Att: Sales
	RLH Industries, Inc.
	936 N. Main St.
	Orange, CA 92867
By Phone:	Local 714-532-1672
	Toll Free 800-877-1672 866-DO-FIBER
By Email:	info@fiber o pticlink.com
By Fax:	714-532-1885

Technical Support

By Email:	support@fiber o pticlink.com
By Phone:	Toll Free 855-754-2497 855-RLH-24X7